

# SOMA™ 1130

COFFEE TABLE

## INSTRUCTION MANUAL

**LET'S GET STARTED.**

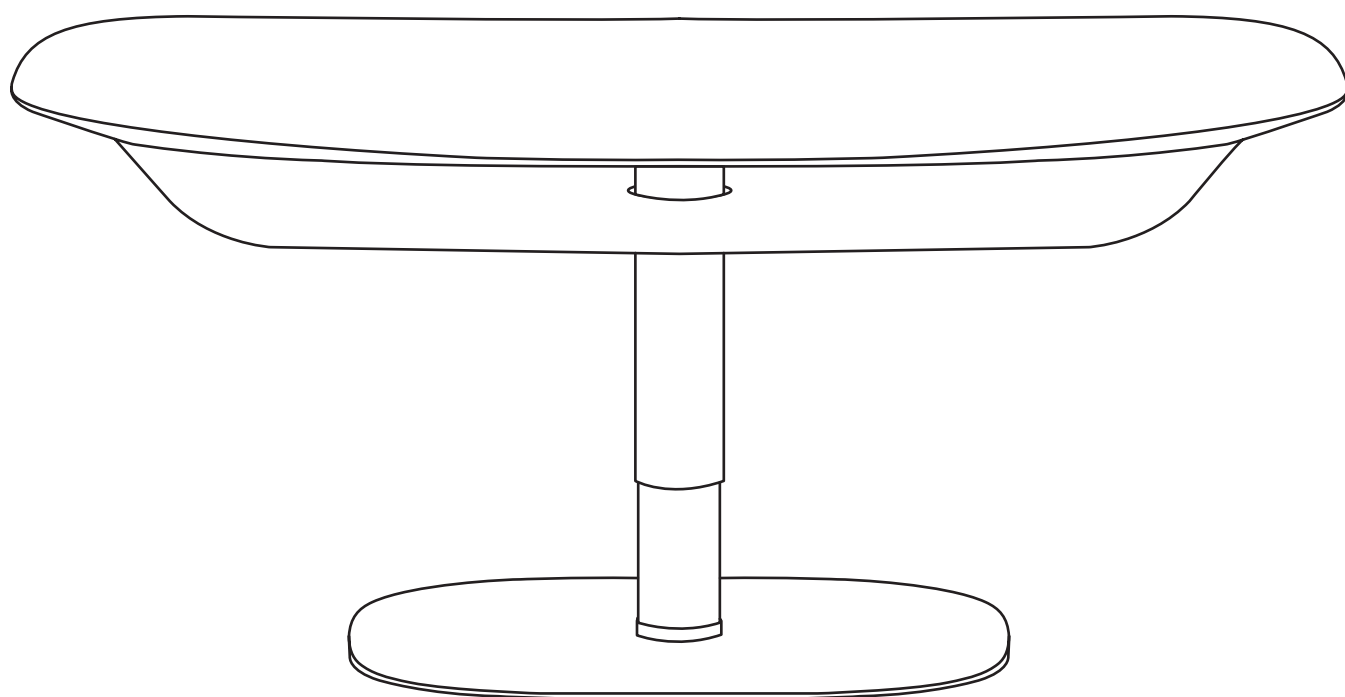

DESIGN JEFF BARE

**BDi**

BDIUSA.COM

Congratulations on the purchase of your Soma Coffee Table 1130 from BDI. Your coffee table has been designed to provide a lifetime of enjoyment. This manual will provide you with assembly instructions and other helpful information to ensure you get the most out of your product. Please save it for future reference.

Your Soma Coffee Table has been engineered for simple assembly. Please follow these directions carefully to prevent any damage.

Should you need further assistance, contact BDI at [customerservice@bdiusa.com](mailto:customerservice@bdiusa.com).

ENJOY!



## HARDWARE AND COMPONENTS

Unpack and identify the parts listed below. If you are missing any hardware, please contact BDI Customer Service at [customerservice@bdiusa.com](mailto:customerservice@bdiusa.com). For all other concerns, please contact your BDI retailer.

The assembly workspace should be a non-marring surface such as carpet. Do not use power tools for the assembly of this product.

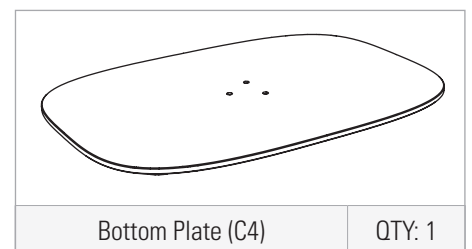
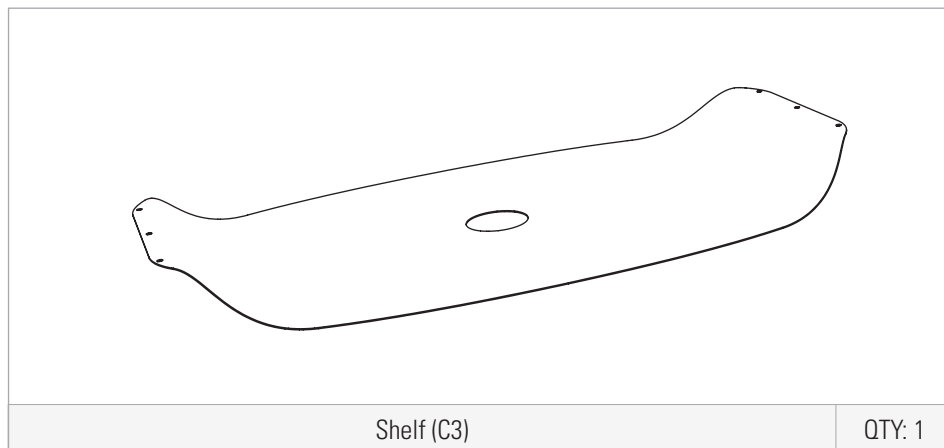
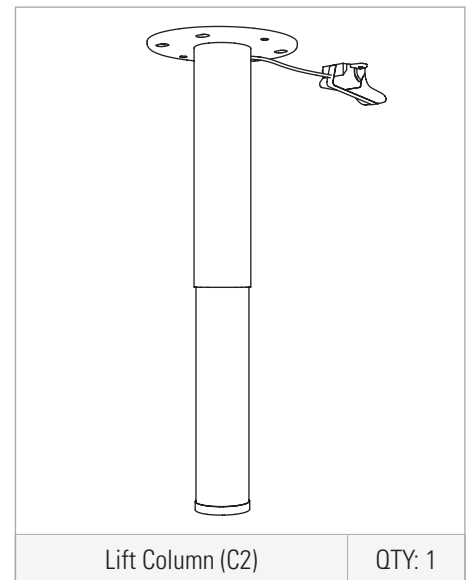
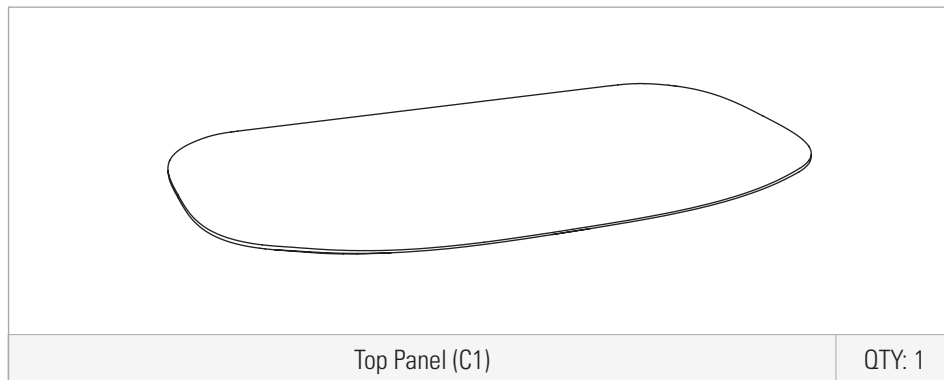
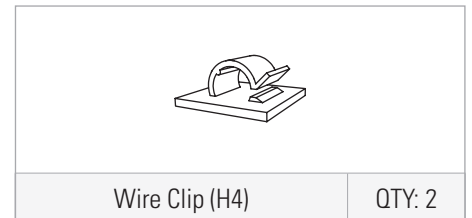
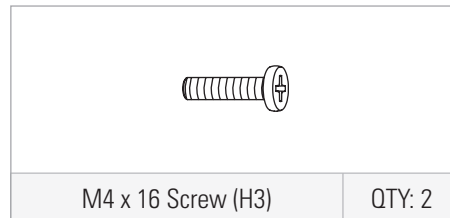
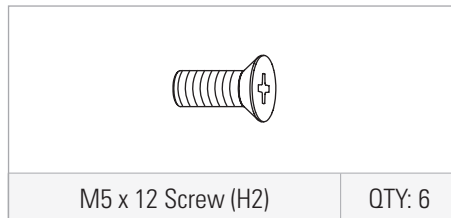
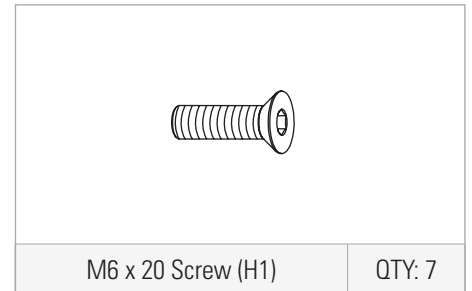
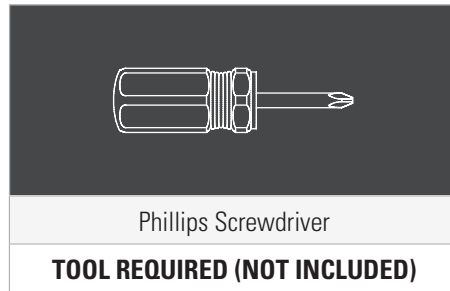
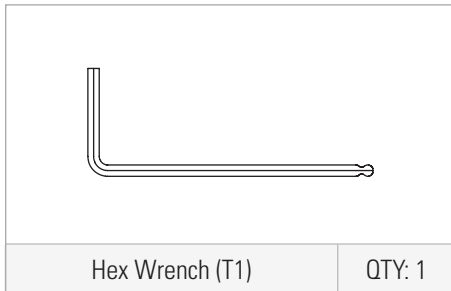

## ASSEMBLY

### STEP 1. DETACH SHELF & BASE FROM TOP

Place the **Top Panel (C1)** upside down on a soft, flat surface. Remove the 3 Silver Screws connecting the **Bottom Plate (C4)** with a **Hex Wrench (T1)**. Discard these screws.

Remove the **6 Screws (H2)** connecting the **Shelf (C3)** to the **Top Panel (C1)** with a **Phillips Screwdriver**. Set these screws aside for later use.

	HEX WRENCH – T1	QTY 1
	PHILLIPS SCREWDRIVER <b>NOT INCLUDED</b>	QTY 1

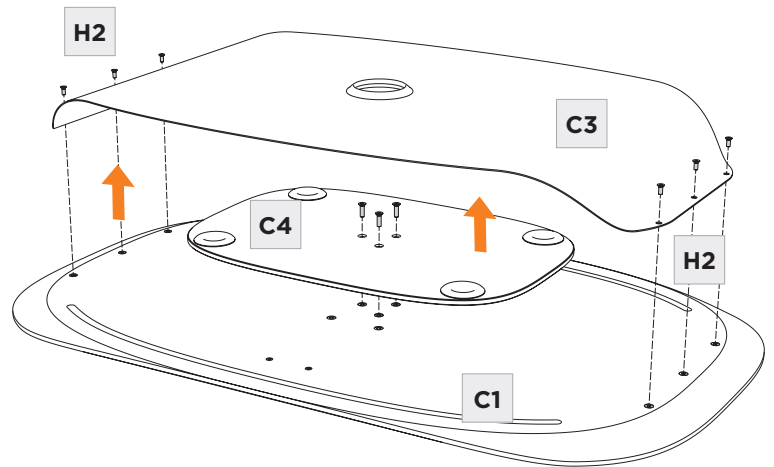



## ASSEMBLY

### STEP 2. ATTACH LIFT COLUMN

Place the **Lift Column (C2)** on the **Top Panel (C1)** and ensure it is in the correct orientation to allow the handset to reach the threaded holes. Mount the **Lift Column (C2)** with **4 Screws (H1)**. Tighten with **Hex Wrench (T1)**. Mount the Lever with **2 Screws (H3)**. Tighten with **Phillips Screwdriver (not included)**.

**Do NOT remove the tape on Lever.**

	HEX WRENCH – T1	QTY 1
	SCREW – H1	QTY 4
	SCREW – H3	QTY 2

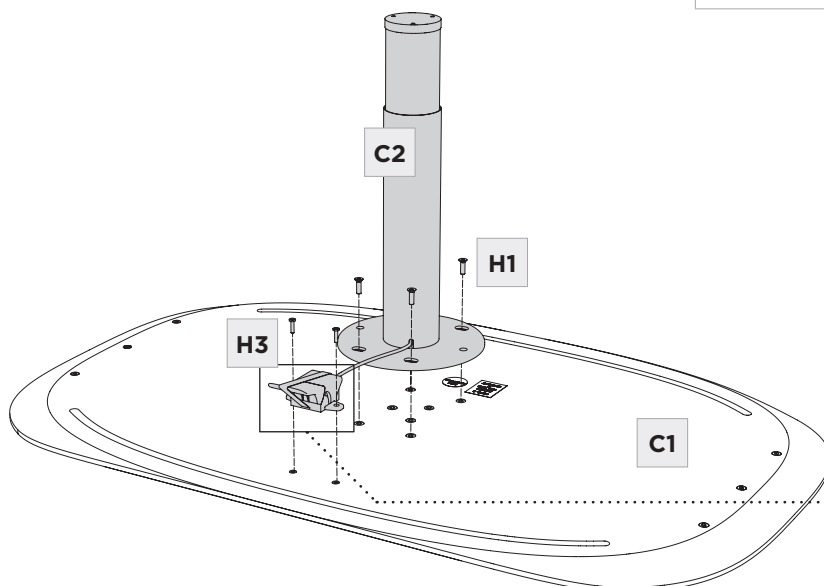

## CAUTION

**Do not remove tape on lever until assembly is complete.**

Pressing the lever will release and extend the column. This should only be done once the base is fully installed. Do not lean or stand over the column during assembly to avoid risk of injury.



### STEP 3. SECURE WIRES

### ASSEMBLY

Secure any wires with the adhesive backed **Wire Clips (H4)** where needed.

	WIRE CLIP – H4	QTY 1-2
---	----------------	------------

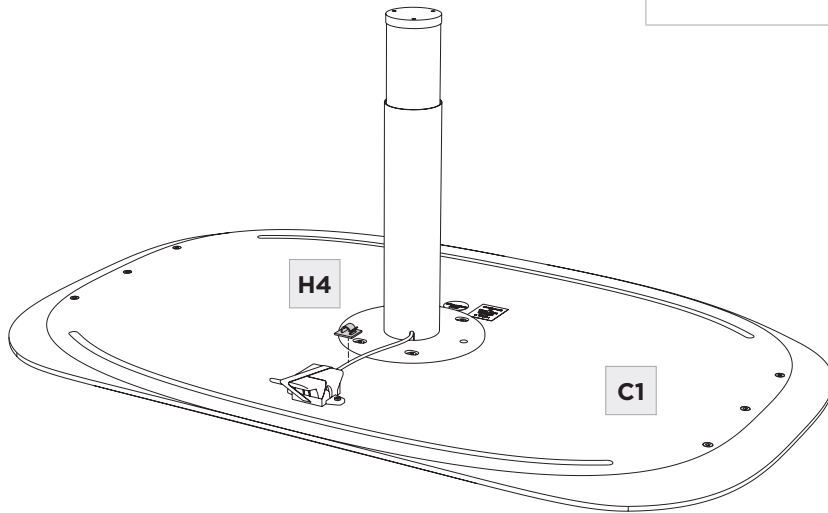

### STEP 4. ATTACH SHELF

### ASSEMBLY

Carefully slide the **Shelf (C3)** over the **Lift Column (C2)**. Attach the **Shelf (C3)** with **6 Screws (H2)**. Tighten with **Phillips Screwdriver**.

You may need to loosen the column screws and adjust its position or slide the shelf up or down on the column to align the shelf mounting holes.

	PHILLIPS SCREWDRIVER <b>NOT INCLUDED</b>	QTY 1
	SCREW – H2	QTY 6

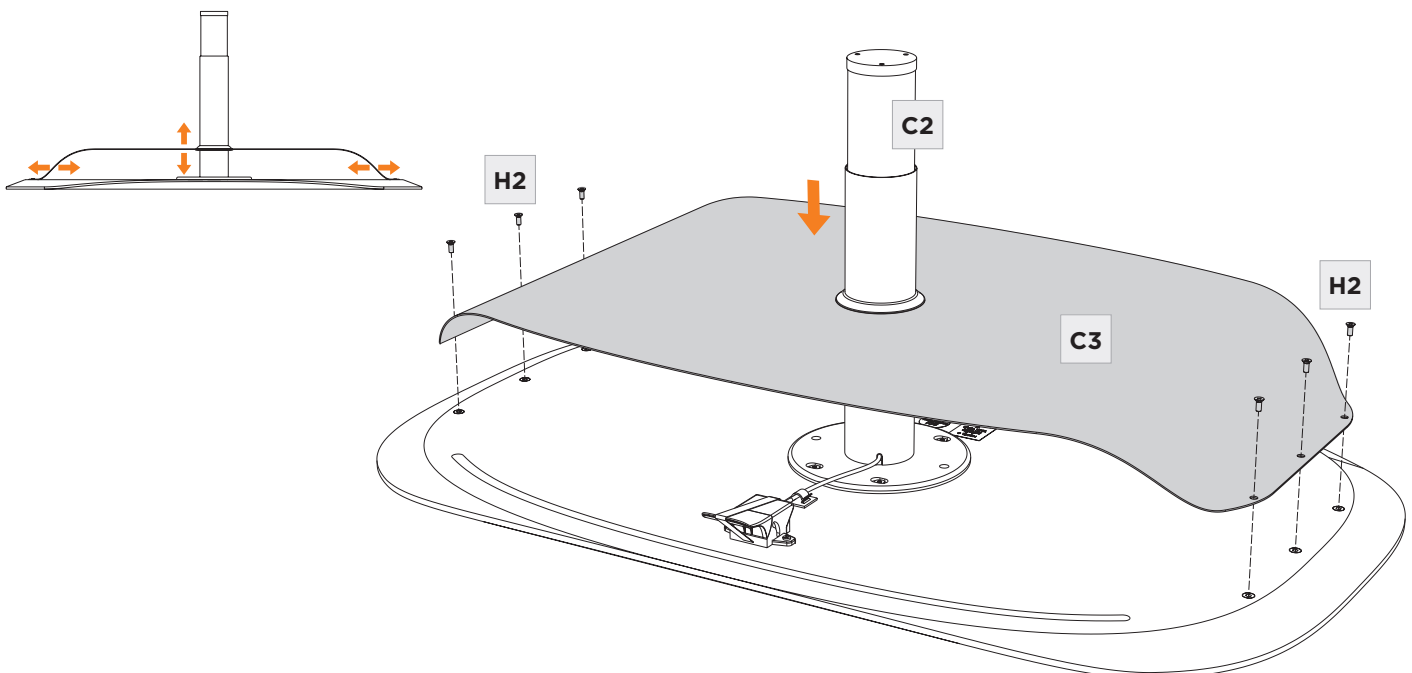

Attach the **Bottom Plate (C4)** to the **Lift Column (C2)** using **3 Screws (H1)**. Tighten with **Hex Wrench (T1)**.

You may need to loosen the column mounting screws and rotate it slightly to align the base straight.

	HEX WRENCH – T1	QTY 1
	SCREW – H1	QTY 3

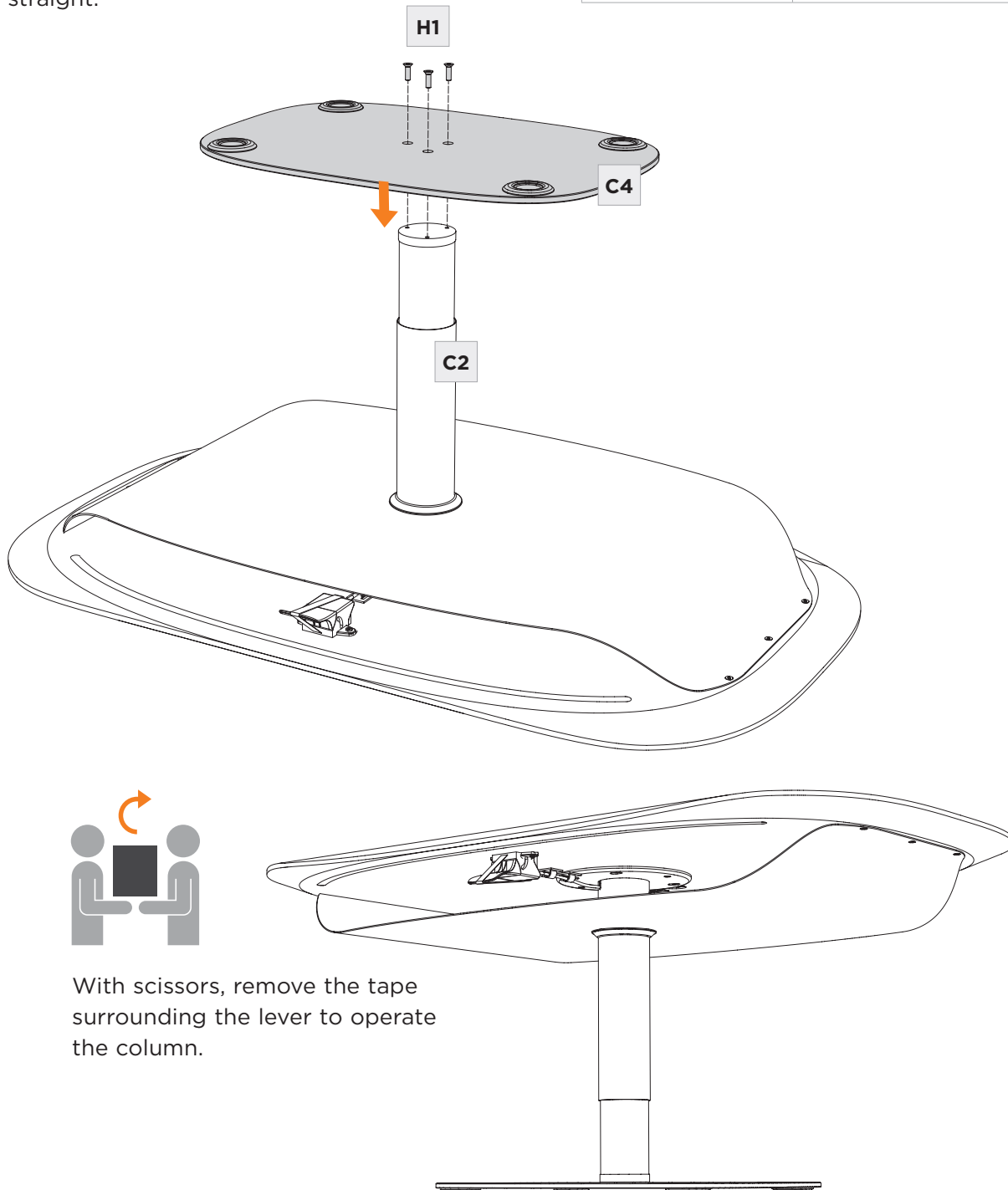

With scissors, remove the tape surrounding the lever to operate the column.

Your BDI furniture has been constructed with the finest materials, manufactured with care and is designed to last a lifetime. Regular care of your furniture will prolong your enjoyment and keep it looking its best. Here are some general tips for taking care of BDI furniture. Your surfaces may vary.

### **GLASS**

The glass surface is maintained using household glass cleaner and a paper towel or cloth.

### **SATIN-ETCHED GLASS**

This uniquely smooth-to-the-touch glass surface can be regularly maintained using household glass cleaner and a paper towel or cloth. Minor scratches or scuffs not eliminated using paper towel or cloth can usually be removed by using a 'Magic Eraser'. Magic Eraser is a melamine foam product available at any grocery store or home improvement center. Dampen the entire glass surface and the Magic Eraser, then rub the entire glass surface in broad, even strokes using moderate pressure. Clean and dry the surface with a paper towel. Check for results and repeat as necessary.

Any scratches or scuffing not eliminated by one of the above methods can often be addressed by 'refreshing' the glass. This is a process that should not be required more than once per 6-12 months. See this brief video for the simple method: [www.bdiusa.com/glass](http://www.bdiusa.com/glass)

### **WOOD**

Wood surfaces should be cleaned with a slightly damp (not saturated) cloth or paper towel. Do not use glass cleaner on wood. If moisture remains, dry the surface with another cloth. If needed, a gentle non-abrasive cleanser may be used, but be sure to wipe away all cleaner residue and dry the surface with a cloth.

BDI's wood finishes feature natural hardwood solids and veneers. Wood is a product of nature and—unlike man-made materials that can be manufactured to strict and consistent specifications—has natural imperfections that are part of its appeal and character. Every piece of wood differs from every other, even when coming from the very same tree. As such, variation in grain, texture and tone should be expected from one panel or piece of furniture to the next.

While BDI's stained wood finishes are stable in tone & appearance, all finishes are subject to some degree of discoloration with prolonged exposure to direct sunlight. Please take care to avoid positioning your BDI cabinet in any area with extensive direct sunlight. To learn more about the features of natural wood, visit [www.bdiusa.com/wood](http://www.bdiusa.com/wood)

### **METAL, PORCELAIN, & PAINTED SURFACES**

Surfaces should be cleaned with a slightly damp (not saturated) cloth or paper towel. If moisture remains, dry the surface with another cloth. If needed, a gentle non-abrasive cleanser may be used, but be sure to wipe away all cleaner residue and dry the surface with a cloth.

## WARRANTY

BDI warrants to the original purchaser that for the below-stated warranty term, BDI will repair or replace any product, part, or component covered by this warranty that fails under normal use as a result of a defect in material or workmanship. BDI will repair or replace the aforementioned product, part or component with a comparable product, part or component. The decision to repair or replace will be at BDI's sole discretion.

BDI furniture is warranted for three (3) years from the date of purchase as shown on your sales receipt. The warranty period starts from the date of purchase. This warranty extends only to the original purchasers who acquire new products from BDI Authorized Resellers. Any product, part, or component must have been assembled, installed, used, and maintained according to BDI's published instructions to be eligible for warranty coverage. Any modification to the original product voids the warranty.

To view BDI's complete warranty information, visit [www.bdiusa.com/warranty](http://www.bdiusa.com/warranty)

## PRODUCT REGISTRATION

Registering your new BDI product allows us to send you important product updates, service information, and helpful hints related to your BDI products. Register today, and you will be entered to win free a BINK table from BDI: [www.bdiusa.com/register](http://www.bdiusa.com/register)



BDIUSA.COM

These distinctive product configurations are protected by US and international patents, trade dress, and/or copyright laws. Soma & BDI are trademarks of Becker Designed, Inc. All rights reserved. ©2022, BDI | V.11.10.2022

Made in China